

Cost-Effective Design

The 505E control is designed to function as the turbine control, system sequencer, operator control panel, and first-out indicator. This encompassing design minimizes external system devices as well as system installation, wiring, and troubleshooting.

This field configurable controller allows major functional changes to be made at site, often by knowledgeable plant personnel, and minor functional changes to be on-line as process changes require. The 505E control's first-out-indicator logic indicates internal as well as external system related alarm and shutdown conditions, greatly simplifying and reducing system troubleshooting.

Communications

The 505E controls can communicate directly with plant Distributed Control Systems and/or CRT-based operator control panels, through two Modbus[®] * communication ports. These ports support RS-232, RS-422, and RS-485 communications using ASCII or RTU Modbus protocols.

Communications between the 505E and a plant DCS can also be performed through hardwired connections. Since all 505E PID setpoints can be controlled through analog input signals, interface resolution and control is not sacrificed.

*—Modbus is a trademark of Schneider Automation Inc.

System Protection

- Integral Overspeed Protection Logic
- First-out Indication (10 individual shutdown inputs)
- Turbine Operating Envelope Limiters
- Bumpless transfer between control modes if a transducer failure is detected
- Local/Remote Control priority and selection
- Failsafe Shutdown Logic

Control

The following PIDs are available to perform as process controllers or limiters:

- Speed/Load PID (with Dual Dynamics)
- Extraction / Admission PID
- Auxiliary PID (limiter or control)
- Cascade PID (Header Pressure or Tie-Line Control)

Control Specifications

INPUTS

- Power: 18–32 Vdc, 90–150 Vdc, 88–132 Vac (47–63 Hz), 180–264 Vac (47–63 Hz)
- Speed: 2 MPUs (1–30 Vrms) or proximity probes (24 Vdc provided), 0.5 to 15 kHz
- Discrete Inputs: 16 Contact Inputs (4 dedicated, 12 programmable)
- Analog Inputs: 6 Programmable Current Inputs (4–20 mA)

OUTPUTS

- Valve/Actuator Drivers: 2 Actuator Outputs (4–20 mA or 20–160 mA)
- Discrete Outputs: 8 Relay Outputs (2 dedicated, 6 programmable)
- Analog Outputs: 6 Programmable Current Outputs (4–20 mA)

COMMUNICATION

- Serial: 2 Modbus (ASCII or RTU) Comm Ports (RS-232, RS-422, or RS-485 compatible)

Control Accessories

Control Assistant (Configuration Management Tool)

The Woodward Control Assistant software program is a computer-based service tool that can be used with the 505E control to upload, save, and download controller configurations. Optionally, this service tool can also be used to trend unit parameters, to compare differences in configuration files, and to verify if control settings have been changed.

Functionality

The 505E's control capabilities are:

- Speed/Frequency Control
- Extraction / Admission Header Pressure Control
- Turbine or Generator Load Control or Limiting
- Turbine Inlet Header Pressure Control or Limiting
- Turbine Exhaust Header Pressure Control or Limiting
- Plant Import/Export Power Control or Limiting
- Isochronous Load Sharing between units (with DSLC™ control)

Features

- Critical Speed Avoidance (3 speed bands)
- Auto Start Sequence (hot & cold starts)
- Valve Limiter(s)
- Security (Program is Password Protected)
- Dual Speed/Load Dynamics
- First-Out Indication (Shutdowns)
- Zero Speed Detection with proximity probe (< 0.5 Hz)
- Peak Speed Indication for overspeed trip
- Two Programmable Functions Keys on the 505E's front panel
- Two independent Modbus comm links
- Remote analog setpoints for Speed/Load, Ext/Adm, Aux, and Cascade
- Program upload/download capability
- Feed-forward decoupling algorithm for compressors

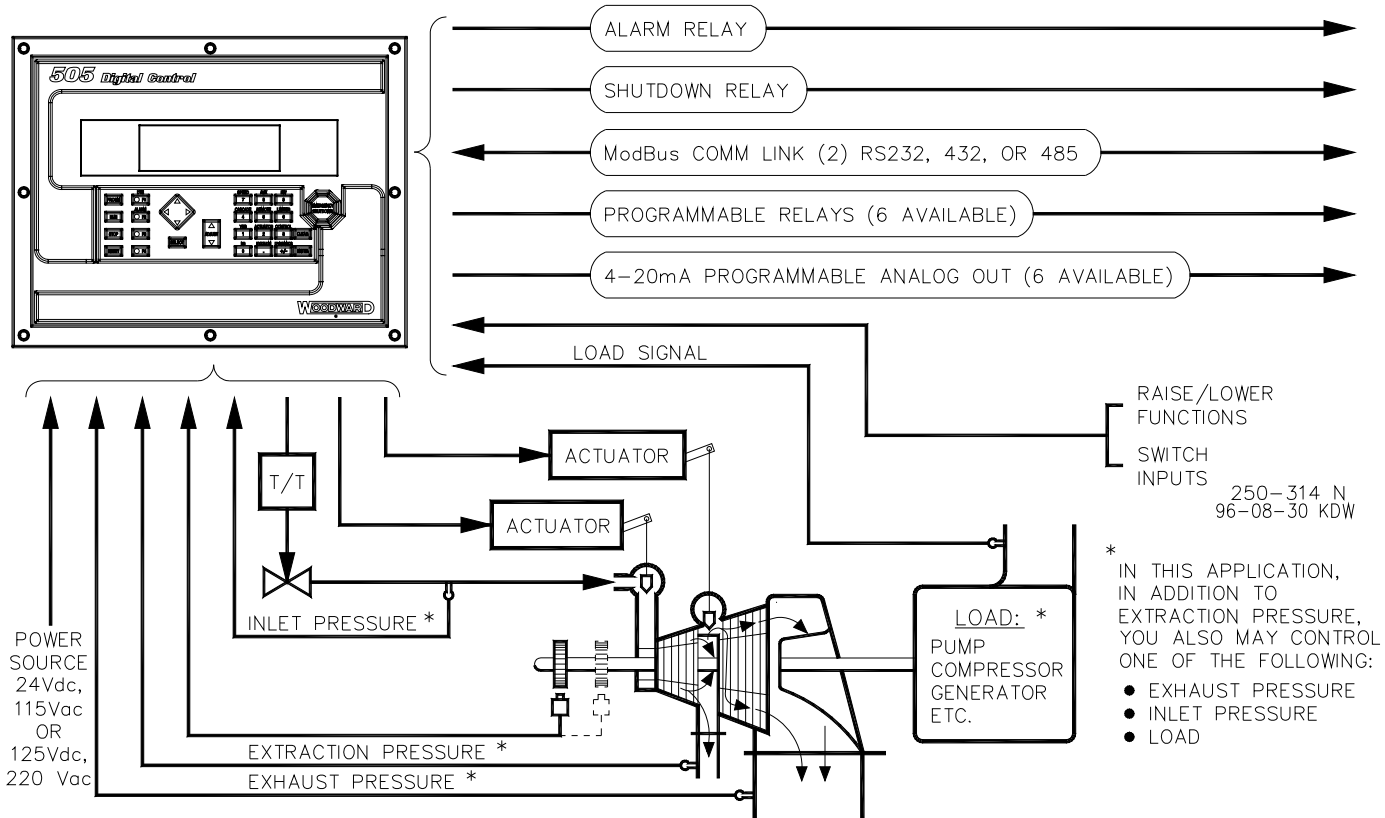

Redundant Controlled Single Valve Steam Turbine

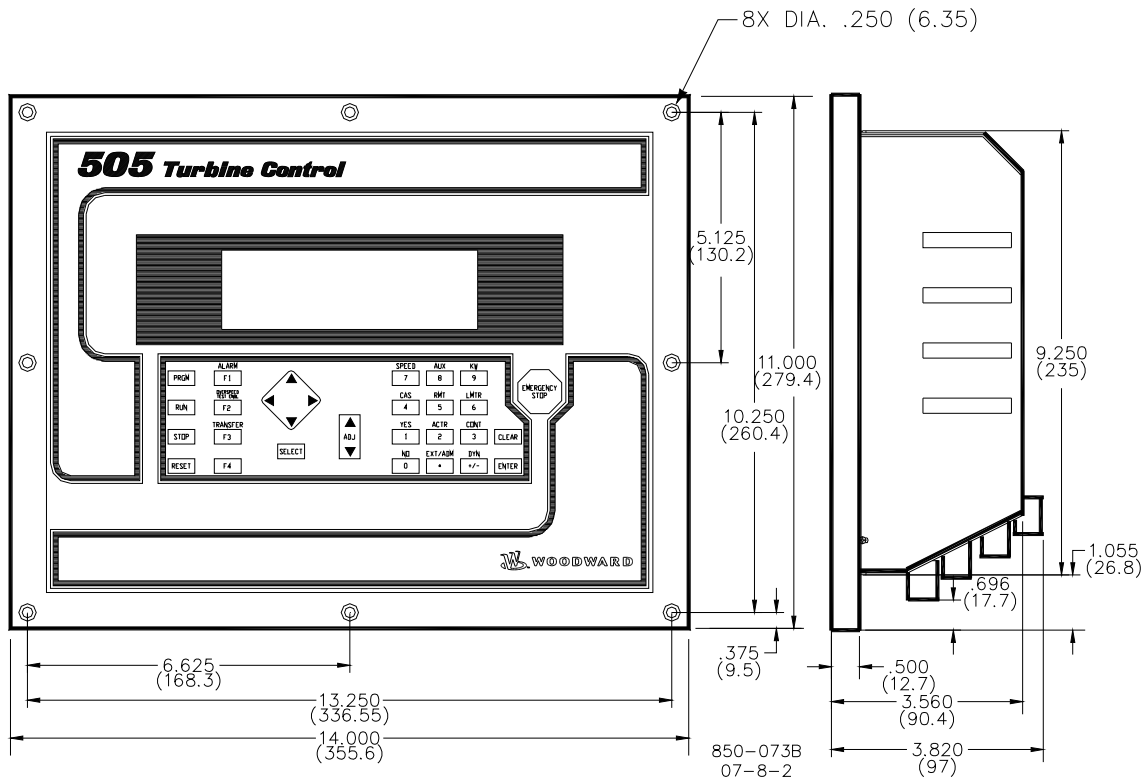

505E Dimensions
(Do not use for construction)

Operating Conditions

- -25 to +65 °C ambient air temperature range
- Optional NEMA type 4 (watertight and dust-tight, indoor/outdoor) enclosure for bulkhead mounting with a temperature range from -25 to +55 °C
- Approximate dimensions 14L x 11H x 4D inches (356 x 279 x 102 mm)
- Approximate bulkhead enclosure dimensions 20L x 20H x 7.6D inches (508 x 508 x 193 mm)
- Humidity: Lloyd's ENV2 test #1
- Dry heat: Lloyd's ENV3
- Salt fog: US MIL-STD-810 method 509.2 procedure 1
- Shock: meets US MIL-STD-810C, method 516.2-1, procedure 1B
- Vibration: Lloyd's ENV2 test #1
- Certifications: CE (18–32 Vdc version only), UL, & cUL

Pollution Resistance

- Particulate Pollution Resistance: IEC 664-1 Pollution Degree 2 (Normally only nonconductive pollution occurs. Temporary conductivity caused by condensation is to be expected.)
- Gaseous Pollution Resistance: The polyacrylate conformal coating withstands NO₂, CO₂, SO₂, and H₂S gases per IEC 60068-2-60:1995 Part 2.60 Methods 1 and 4 (Flowing Mixed Gas Corrosion Test). It will withstand levels typical of telecommunications and computer installations as defined by Battelle Labs Class III (between IEC 60721-3-3 classification 3C1 and 3C2, light industrial to urban industrial, heavy traffic).

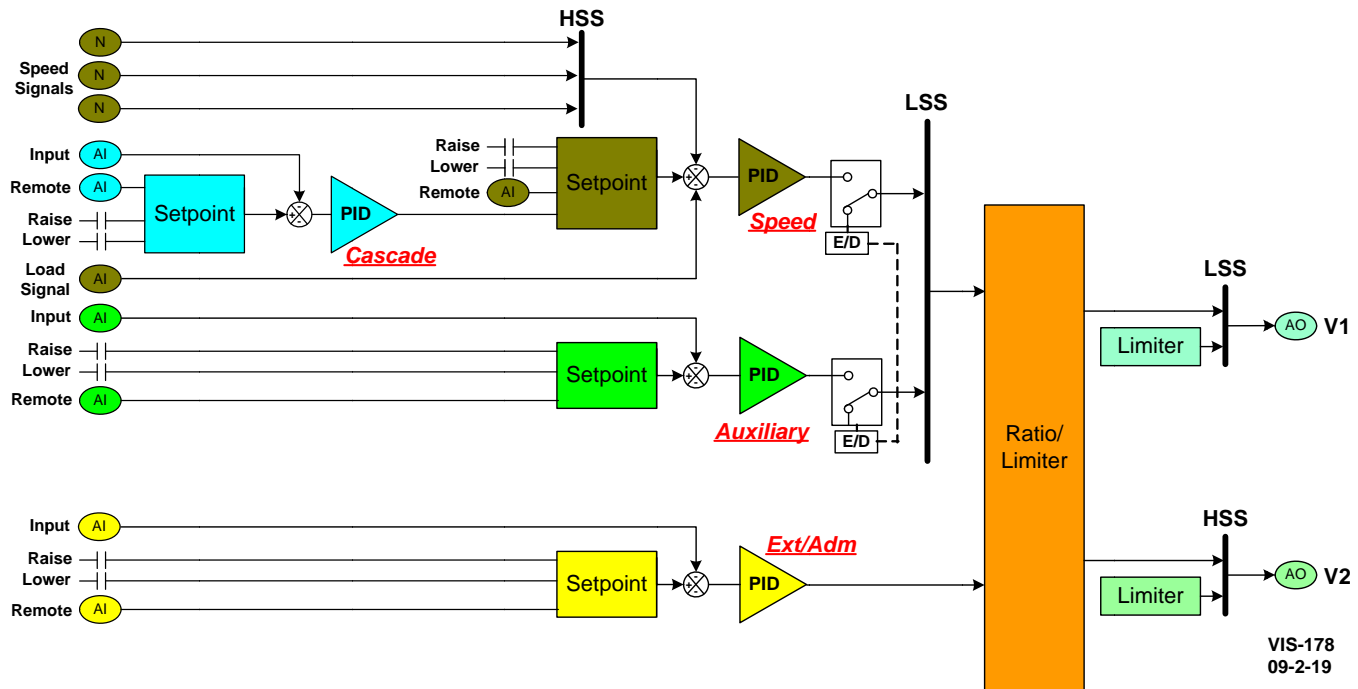

Basic Functional Control Diagram



PO Box 1519, Fort Collins CO, USA 80522-1519
 1000 East Drake Road, Fort Collins CO 80525
 Tel.: +1 (970) 482-5811 • Fax: +1 (970) 498-3058
www.woodward.com

Distributors & Service

Woodward has an international network of distributors and service facilities. For your nearest representative, call the Fort Collins plant or see the Worldwide Directory on our website.

This document is distributed for informational purposes only. It is not to be construed as creating or becoming part of any Woodward contractual or warranty obligation unless expressly stated in a written sales contract.

© Woodward 2009, All Rights Reserved

For more information contact:

2011/4/Colorado